

ICC-ES Evaluation Report

ESR-5055

Reissued April 2024

Subject to renewal April 2025

ICC-ES Evaluation Reports are not to be construed as representing aesthetics or any other attributes not specifically addressed, nor are they to be construed as an endorsement of the subject of the report or a recommendation for its use. There is no warranty by ICC Evaluation Service, LLC, express or implied, as to any finding or other matter in this report, or as to any product covered by the report.

Copyright © 2024 ICC Evaluation Service, LLC. All rights reserved.

<p>DIVISION: 31 00 00— EARTHWORK</p> <p>Section: 31 60 00— Special Foundations and Load-Bearing Elements</p>	<p>REPORT HOLDER:</p> <p>GRIP-TITE MANUFACTURING CO., LLC.</p>	<p>EVALUATION SUBJECT:</p> <p>GRIP-TITE® WALL ANCHOR SYSTEM</p>	
--	--	---	---

1.0 EVALUATION SCOPE

Compliance with the following codes:

- 2021, 2018, 2015, and 2012 [International Building Code® \(IBC\)](#)

Properties evaluated:

- Structural

2.0 USES

Grip-Tite® Wall Anchor System is intended for exterior use as a tie-back device to stabilize foundation walls affected by leaning, tilting, bowing, or cracking.

3.0 DESCRIPTION

3.1 General: Grip-Tite® Wall Anchor System consists of the following components described in Sections 3.2 to 3.7 and as illustrated in [Figure 1](#).

3.2 Interior Wall Plate: The interior wall plate is part of an assembly that is 18-¼ -inches (46.36 cm) x 11-inches (27.94 cm) or 28-inches (71.12 cm) x 12-½ -inches (31.75 cm) formed steel plate. See [Table 1](#) for more specifications. The maximum distance that the wall plate can span is 8-inches (20.32 cm). The interior wall plate is hot-dipped galvanized in accordance with ASTM A123M and as illustrated in [Figure 3](#).

3.3 Flat Plate Washer: The flat plate washer is part of the interior wall assembly that is 4-inches (10.16 cm) x 4-inches (10.16 cm) x ¼ -inch (0.64 cm) thick, manufactured from ASTM A36 Steel. For coating, see [Table 3](#).

3.4 Exterior Soil Anchor: The exterior soil anchor is part of an assembly made from two (2) pieces of formed steel plate. See [Table 2](#) for specifications. The exterior soil plate is hot-dipped galvanized in accordance with ASTM A123M and as illustrated in [Figure 4](#).

3.5 Threaded Rod: The threaded rod is ¾ -inch (1.91 cm) – 10 UNC cold rolled round bar. The threaded rod is manufactured per SAE J403 Grade 1018, with ultimate tensile strength of 63 ksi (434 MPa) and yield strength is 53 ksi (365 MPa). The rod is hot-dipped galvanized in accordance with ASTM A153.

3.6 Beveled Washers and Nut: 1-¾ -inches (4.45 cm) Beveled washer manufactured per ASTM F436. A ¾ -inch (1.91 cm) square nut conforming to ASTM A563 Grade A. For coating, see [Table 3](#).

3.7 Threaded Coupler: The threaded coupler is 1-inch (2.54 cm) o.d x 3-inch (7.62 cm) long and manufactured from ASTM A513-5 Grade 1020 steel with ultimate tensile strength of 86 ksi (593 MPa) and yield strength of 68 ksi (469 MPa). The 3/4-inch (1.91 cm) -10 UNC threads extend 1-1/8 -inches (2.86 cm) from each end. For coating, see [Table 3](#).

4.0 DESIGN AND INSTALLATION

4.1 Design: Structural calculations shall be submitted to the code official on a job-specific basis with consideration to the existing foundation wall, soil conditions, and overall system integrity.

The Grip-Tite® Wall Anchor System shall be designed as a tie-back device to stabilize foundation walls with the allowable tension loads in accordance with [Table 1](#). The design loads shall be determined in accordance with the applicable sections of the IBC.

4.2 Installation: Grip-Tite® Wall Anchor System is installed by inserting a steel rod through the wall into the outside earth. A soil anchor is then attached to the steel rod through a vertical hole in the ground. An interior wall plate then secures the rod inside the foundation wall, as illustrated in [Figure 2](#). [Table 4](#) lists specific wall heights and soil variability references and can be used together with the soil test report to determine important installation information such as wall plate/anchor rod height, allowable anchor spacing, distance and depth, and allowable lateral bearing capacity.

Grip-Tite® Wall Anchor System shall be installed in accordance with the applicable code, this report, the manufacturer's published installation instructions, and the approved construction documents prepared by a registered design professional. A copy of the manufacturer's published installation instructions and the approved drawings shall be available at all times on the jobsite during installation.

5.0 CONDITIONS OF USE:

The Grip-Tite® Wall Anchor System described in this report complies with or is a suitable alternative to what is specified in, those codes listed in Section 1.0 of this report, subject to the following conditions:

- 5.1** Installation shall comply with this report, the applicable code, and the manufacturer's published installation instructions. If there is a conflict between the manufacturer's installation instructions and this report, this report governs.
- 5.2** Installation shall be performed by trained installers certified by Grip-Tite Manufacturing Co., LLC.
- 5.3** A site survey is necessary of the area where the anchors will be placed to locate any possible interferences such as utilities, plumbing, electric, or phone lines.
- 5.4** A Geotechnical Investigation shall be conducted to evaluate the adequacy, strength, and stability of the load-bearing soils to determine location, depth, and spacing for the anchors. This requirement may be waived by the Building Official when satisfactory data from the adjacent area is available.
- 5.5** A registered design professional shall prepare calculations and/or design for the Grip-Tite® Wall Anchor System in accordance with the requirements of ASCE 7 as indicated in the IBC.
- 5.6** Special inspection requirements shall be determined by the Building Official.
- 5.7** The soil that has been removed for the Anchor hole installation shall be replaced and compacted or filled to complete the installation.
- 5.8** The Grip-Tite® Wall Anchor System is for axial tension application only.
- 5.9** The following items are beyond the scope of this report, and they are related to the design and installation of the Grip-Tite® Anchor Wall System:
 - Design, calculations, and details for the foundation wall verifying compliance with this report.
 - The installer's qualifications.
 - Soil Stability and bearing strength.

6.0 EVIDENCE SUBMITTED

- 6.1** Design calculations in accordance with ANSI/AISC 360.
- 6.2** Quality documentation in accordance with [ICC-ES Acceptance Criteria for Quality Documentation \(AC10\)](#), dated May 2022.

7.0 IDENTIFICATION

- 7.1 The ICC-ES mark of conformity, electronic labeling, or the evaluation report number (ICC-ES ESR-5055) along with the name, registered trademark, or registered logo of the report holder [and/or listee] must be included in the product label. [Electronic labeling is the ICC-ES web address (www.icc-es.org); specific URL related to the report; or the ICC-ES machine-readable code placed on the aforementioned items.]
- 7.2 In addition, product labeling shall include the name and address of the report holder (Grip-Tite Manufacturing Co., LLC) and product identification.
- 7.3 The report holder’s contact information is the following:

GRIP-TITE MANUFACTURING CO., LLC
505 EAST MADISON STREET
WINTERSET, IOWA 50273
(515) 462-1313
www.griptite.com

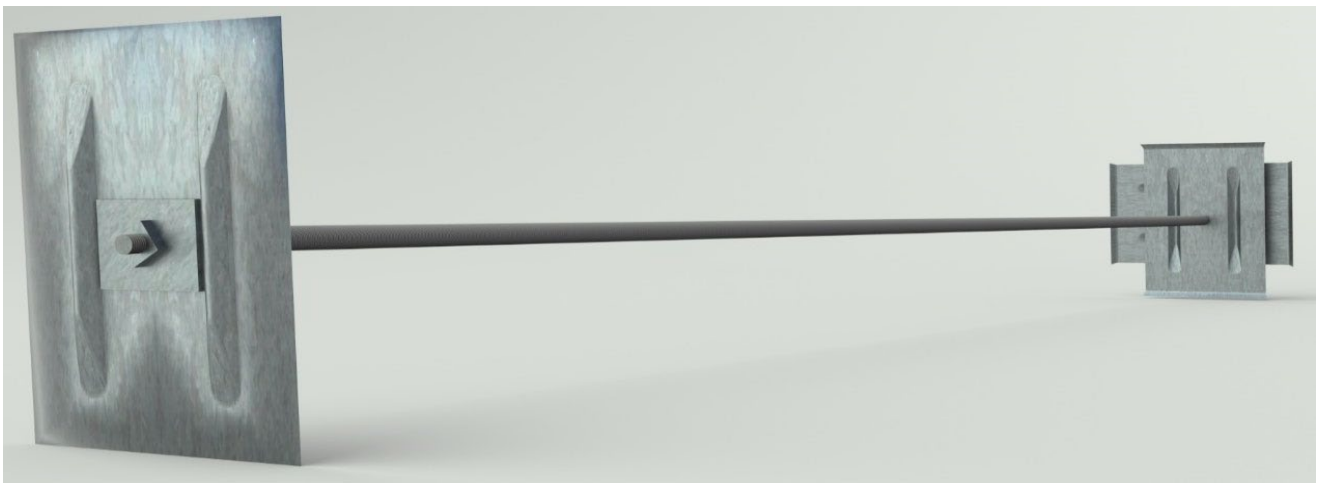

FIGURE 1—GRIP-TITE[®] WALL ANCHOR SYSTEM ASSEMBLY

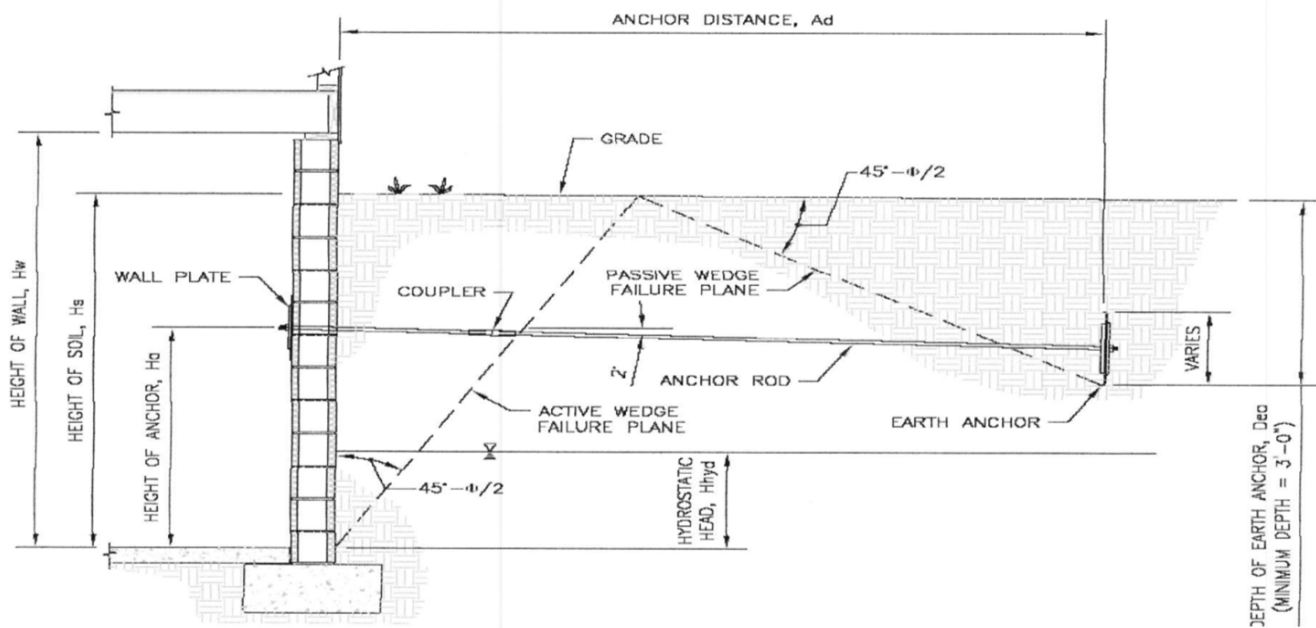

FIGURE 2—TYPICAL WALL ANCHOR ASSEMBLY

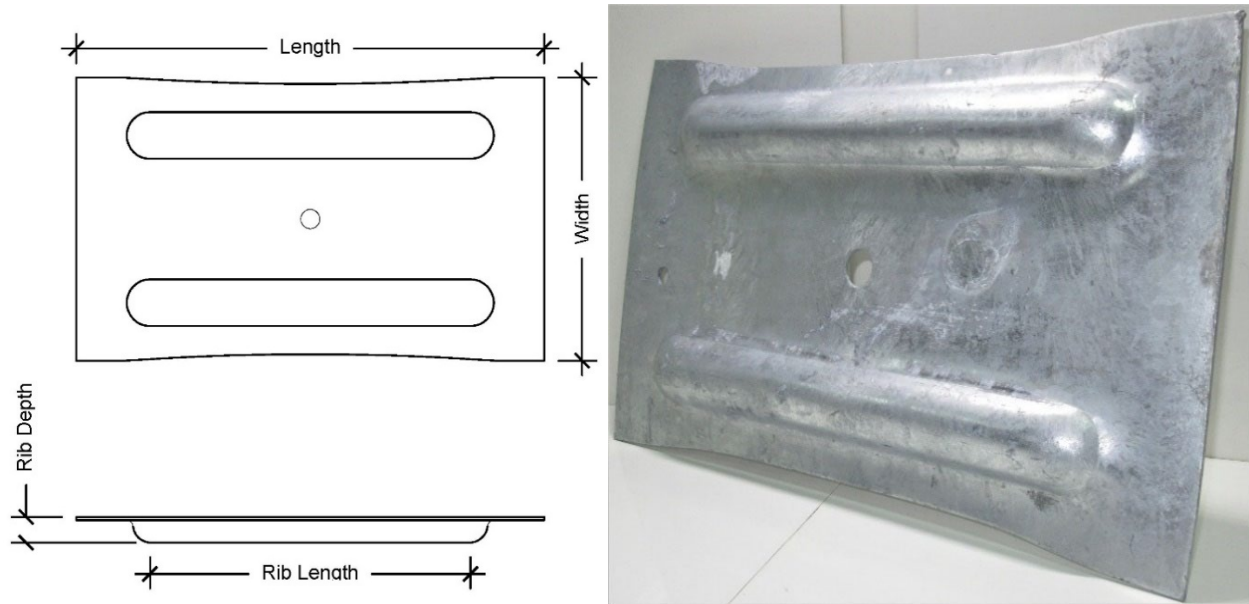

FIGURE 3—INTERIOR WALL PLATE

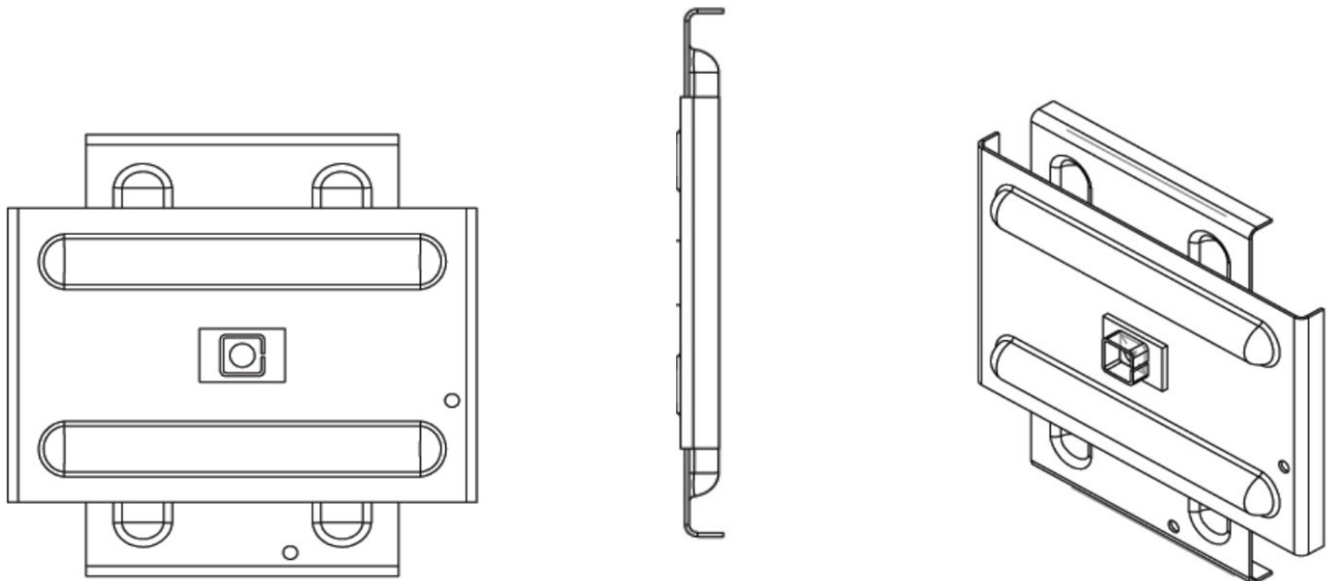

FIGURE 4—EXTERIOR SOIL ANCHOR

TABLE 1—INTERIOR WALL PLATE ALLOWABLE TENSION LOAD

Interior Wall Plate Number	Wall Plate Size & Min. Thickness (inch)	Steel	Minimum Rib Depth (inch)	Minimum Rib Length (inch)	Minimum Yield Strength (ksi)	Maximum Allowable Tension Load (lbs.)
GT250P	18- ¹ / ₄ x 11 x 0.136tk.	ASTM A572, Grade 50	1.0	12.5	64.9	9,400
	18- ¹ / ₄ x 11 x 0.131 tk.	ASTM A572, Grade 50	0.83	12.5	67.1	7,290
GT400P	28 x 12- ¹ / ₂ x 0.182tk.	ASTM A572, Grade 50	1.1	19.2	63.3	10,000
	28 x 12- ¹ / ₂ x 0.182tk.	Hot Rolled C1008-C1011	1.1	19.2	51.1	10,000

TABLE 2—EXTERIOR SOIL ANCHOR TYPES

Exterior Soil Anchor Number	Steel	Size (inch)
GT250A	Hot Rolled C1008-C1011 or ASTM A572, Grade 50	16- ¹ / ₂ x 11 x 0.136tk.
GT325A	Hot Rolled C1008-C1011 or ASTM A572, Grade 50	16- ¹ / ₂ x 11 x 0.136tk.
		26- ⁵ / ₁₆ x 12- ¹ / ₂ x 0.187tk.
GT400A	Hot Rolled C1008-C1011 or ASTM A572, Grade 50	26- ⁵ / ₁₆ x 12- ¹ / ₂ x 0.187tk.

TABLE 3—COATINGS

ASTM Standard	Suggested thickness
A153	43 μ m
F2329	
B695 class 25	25 μ m
B633 Fe/Zn 12	12 μ m

TABLE 4—REFERENCE CMU WALL CHARTS AND FRICTION ANGLES ^{1 2}

Wall Height	10 feet	9 feet	8 feet	7 feet	6 feet
Friction Angles	15 Degrees	15 Degrees	15 Degrees	15 Degrees	15 Degrees
	26 Degrees	26 Degrees	26 Degrees	26 Degrees	26 Degrees
	36 Degrees	36 Degrees	36 Degrees	36 Degrees	36 Degrees

1. Refer to the manufacturer’s CMU Wall Charts – Variable Fill Heights – Variable Soil Parameters for installation specifications.
2. Friction angle is denoted as ϕ , as shown in Figure 1.